

FRAME PLAN

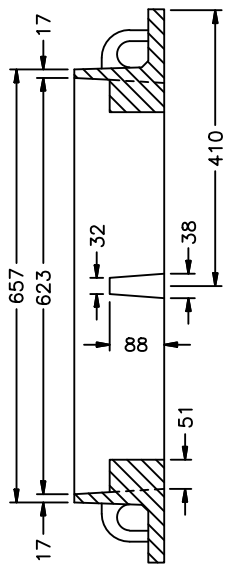

SECTION A-A

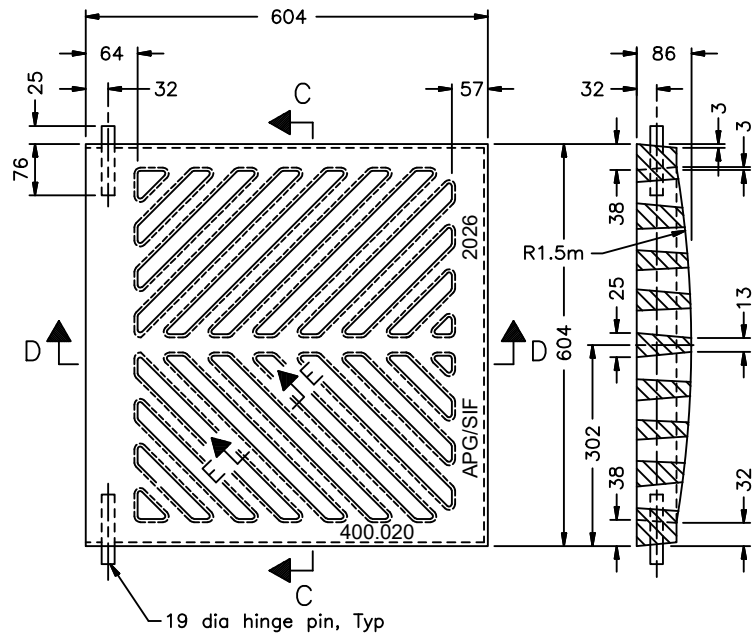

GRATE PLAN

SECTION C-C

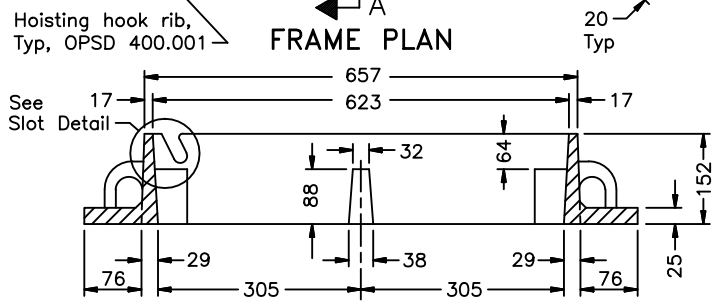

SECTION B-B

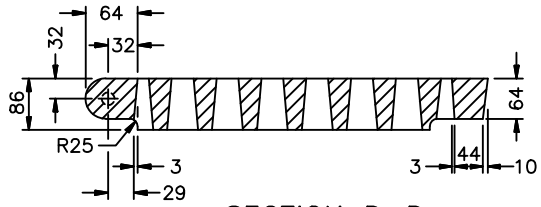

SECTION D-D

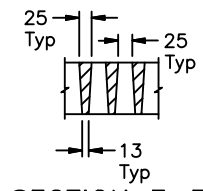

SECTION E-E

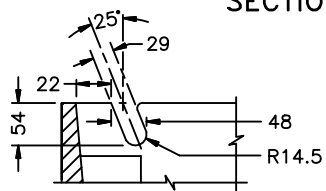

SLOT DETAIL

**NOTES:**

1. This OPSD shall be read in conjunction with OPSD 610.010 and 610.020.
2. All dimension are in millimeter unless otherwise shown.
3. Material: Cast Iron ASTM A48 Clas 30B
4. Tolerance should be  $\pm 0.0625$  , unless otherwise specified.

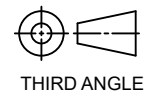
REV. NO	DATE	SIGN	DATE	 <p><b>APG Castings Inc.</b> Suite 232, 14-3650 Langstaff Rd, Woodbridge, ON, L4L 9A8</p>			
DRAWN	T.JANA	17.10.2025					
CHECKED	M. GANGULY	17.10.2025					
QA							
MFG				<p><b>TITLE :- OPSD 400.020</b></p>			
APPRVD BUYER							
ESTMTD. WT				<p>SCALE NTS</p>  <p>THIRD ANGLE</p>	<p>DWG NO :-</p> <p>LOAD RATING :</p>	<p>Material:- CAST IRON</p> <p>PAINT: UNPAINTED</p>	<p>SHEET : 1 OF 1</p>